

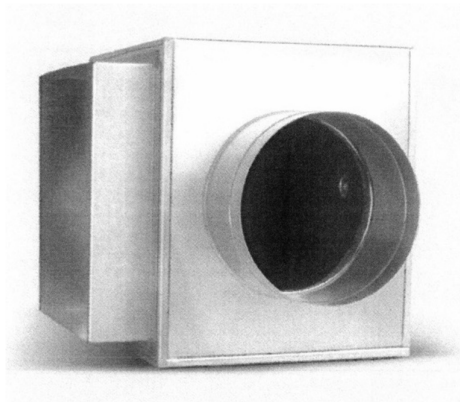

PLENUM BOX FOR SQUARE DIFFUSER

(SARA-PBS)



DIMENSIONS

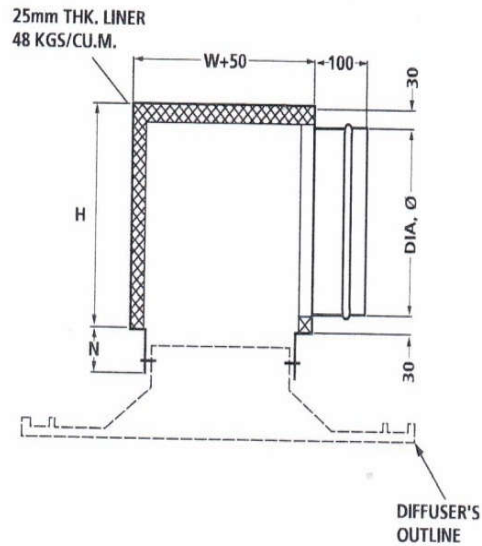

DESCRIPTION

This spigot inlet can fix either on the top or on the side of the box depending on site requirements

H – Height (mm)

N – Neck length (70mm standard)

Ø – Diameter

S – Spigot length (S) 100mm without damper

- Box made of 24 Gage galvanized steel (G90)
- Dimensions H and W in is based on the grill diffuser neck size
- Standard liner – 48kg/m³ density x 25mm thickness.

Ordering

Product code

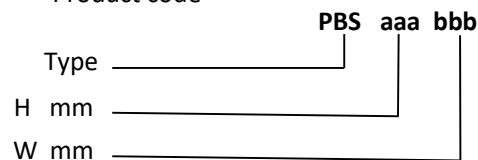

LINER PLENUM BOX

(SARA-LPB)

LPB



DIMENSIONS

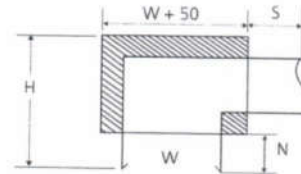
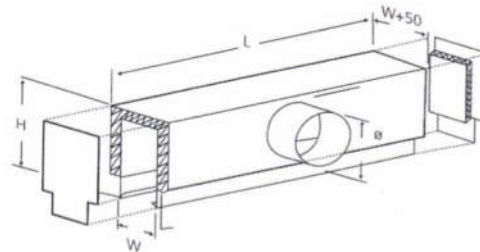

DESCRIPTION

- 24 ga Galvanized steel (G-90)
- Standard liner 48 Kg/m³ density x 25mm thickness
- H – Height (mm)
- L – Length (mm)
- N – Neck length (70 mm standard)
- Ø – Diameter
- S – Spigot length (s) 100mm without damper)
- l – Slot equal 4mm as a standard

- The spigot inlet can fix either on the top or on the side of the plenum box depending on site requirements
- Dimensions H and W is based on the grille/diffuser neck size

Ordering

Product code

